

Design High Gain PHEMT LNA for Wireless Application at 5.8 GHz

Pongot K, Othman A.R, Zakaria Z, Suaidi M.K, Hamidon A.H, Hamidon J.S, Ahmad A

Abstract— This research present a design of a higher gain (68.94dB) for PHEMT LNA using an inductive drain feedback technique for wireless application at 5.8GHz. The amplifier it is implemented using PHEMT FHX76LP transistor devices. The designed circuit is simulated with Ansoft Designer SV. The LNA was designed using inductive drain feedback, inductive generation to the source, and the T-network as a matching technique was used at the input and output terminal. The low noise amplifier (LNA) provides a noise figure 0.64 dB and gain (S_{21}) of 68.94 dB. The output reflection (S_{22}), input reflection (s_{11}) and return loss (s_{12}) are -17.37 dB, -15.77 dB and -88.39 dB respectively. The measurement shows the stability were at 4.54 and 3-dB bandwidth of 1.72 GHz. The input sensitivity is -92 dBm exceeded the standards required by IEEE 802.16.

Keywords- IEEE 802.16; Cascaded and Cascoded LNA; Inductive drain feedback, PHEMT LNA

1. INTRODUCTION

At this point, most of the developing and advanced country used 3G technologies due to the speedy delivery of information to users at a higher bit rate. However, the bit rate of 3G technology reserve at this point is still not enough due to the high demand from consumers, especially in wireless broadband. To overcome this problem, the use of WiMAX technology was introduced to consumers to enable effective connectivity at high bit rate to a new generation of consumer devices for adaptation latest applications that are available in the market (Lowe, 2007).

Pongot K., Ahmad A
Bahagian Sumber Manusia, Majlis Amanah Rakyat (MARA)
Malaysia
kamilpongot@yahoo.com.sg, azmanahmad888@gmail.com

Othman A.R, Zakaria Z, Suaidi M.K, Hamidon A.H, Hamidon J.S
Universiti Teknikal Malaysia Melaka line 1 College / University Name
Malaysia
rani@utem.edu.my, zahriladha@utem.edu.my, kadim@utem.edu.my,
hamid@utem.edu.my, jsamhamidon@yahoo.com.

Groups of telecommunication protocol using WiMAX technology as a new trademark and standards in the provision of mobile and fixed internet access. Residential construction and opening of a planned township enterprises in free zones require high data transfer rate (70 Mbps) and reach (50 km) to meet the needs of high bandwidth voice and data to support the growth of the industry (Othman et al., 2012). WiMAX is a replacement technologies for cellular phone technologies such as UMTS and GSM and can be used to increase capacity of the customer (AbdulRahman, 2008). Therefore, the RF front-end receiver should be design according to the latest specifications to support new trademark as set by the telecommunications protocols and allows it to operate in a multiple of applications on a single device.

Design of LNA amplifiers for RF receiver front-end to obey and comply with the new standards IEEE 802.16 to ensure that the received signal can be processed to obtain information that is transmitted without interference noise. This can only be done when the designers are able to design RF front-end receiver with the best characteristic in the entire system such as the higher gain, low noise figure and sufficient bandwidth to accommodate the needs of the latest applications available in the market for users using WiMAX technology.

To ensure high performance signal reception to meet the standards set by IEEE 802.16, a new design in architecture receiver RF front-end should be introduced to improve the performance of existing systems. Previous researcher reported covering the extension of communication distance for the system up to 50km requires overall gain from the range up to 50 dB (Othman et al., 2010), but to get a better performance for RF front-end receiver, we proposed for overall gain that introduce enhanced up to 65 dB.

For WiMAX standard, the system is designed to accommodate up to 200 channel subscribers while the bandwidth of the system designed is between 1600 to 1700 MHz, which is triple than the standard 20 MHz for 200 sub-carriers. In addition, the noise figure proposed by the IEEE 802.16 (WiMAX) for the RF receiver front-end architecture must be less than 3 dB. The input sensitivity of the system should cover the minimum sensitivity of -80 dBm (Othman et al., 2010).

In this paper, a new topology front end architecture using inductive drain feedback is used to achieve a gain more than 65 dB, noise figure less than 3dB and should provide bandwidth more than 1 GHz is proposed for WiMAX application. Fig 2 shows the architecture configurable for direct conversion RF front-end receiver WiMAX at 5.8 GHz is introduced. The development of combination LNA at the front-end of the receiver will be focused.

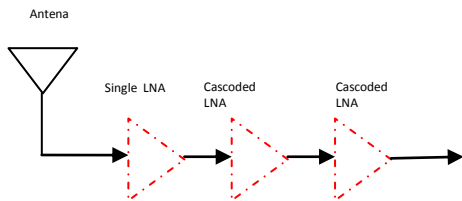

Fig 2. The new architecture for direct conversion RF front-end receiver WiMAX at 5.8 GHz

This configuration consisting of double stages cascoded LNA using inductive drain feedback combined with source inductive degeneration, inductive RF choke placed between the two LNA amplifier and the T matching network at the input and output ports. Were used inductive drain feedback at the cascoded topology has improved the gain of the LNA and will suit at matching output that it also helps in increasing the bandwidth. While the addition of an inductive source generation at cascoded LNA topology enhanced bandwidth, stability and improve input-output matching capabilities. The use of T-matching on a double stage cascoded LNA also has helped reduced the reverse isolation and noise figure.

2. LNA THEORY

Low noise amplifier (LNA) is a key factor in the improved performance of the RF front-end receiver. LNA in the WiMAX receiver application requires sufficient sensitivity to enable the receiver distinguish signal from the surrounding noise and interference to ensure that it can take an information signal sent by the transmitter. The gain, bandwidth, noise figure and linearity are the characteristic that can be controlled by the RF front-end designer that affect directly to the receiver sensitivity. Even so to control such features requires a deep understanding of the device amplifiers, active and passive components, and fabrication details to ensure the LNA amplifiers built to achieve optimal performance and only a slight tradeoff between the characteristic (Sumesh and Ravi, 2012).

However, in this research we only focused on variables such as gain, noise figure, stability, bandwidth, topology, and input and output matching for best performance of LNA amplifiers.

The targeted S-parameter specification for the single LNA cascaded with double stages cascoded LNA amplifier is shown in Table 1.

Table 1. Targeted S-Parameters for a single LNA cascaded with double stages cascoded LNA amplifier

S- parameter	Single LNA cascaded with double stages cascoded LNA
Input reflection S11 (dB)	< -10 dB
Return Loss S12 (dB)	< -10 dB
Forward Transfer S21 (dB)	>+ 65 dB
Output Reflection loss S22 (dB)	<-10 dB
Noise Figure (dB)	< 3 dB
Stability (K)	K > 1
Bandwidth (MHz)	>1000

2.1 Stability , Noise Figure and Power Gain

Stability is one of the important characteristics in designing LNA amplifiers. Determination of stability is essential to avoid oscillation occurs at the operating frequency. The oscillation is possible if either of input or output port impedance has produce a negative real part. This would imply that $\Gamma_{in} > 1$ or $\Gamma_{out} > 1$. This because Γ_{in} and Γ_{out} depend on the source and the load matching network. However, the stability of the amplifier depends on Γ_s and Γ_L as presented as matching network. If low noise amplifiers is not stable, it would become useless since major properties including bandwidth, gain, noise, linearity, DC power consumption and impedance matching can be significantly degraded. For this design, a good stability was achieved (unconditionally stable) by employing the signal flow theory and S-parameter (Pojar, 2001). Alternatively, the amplifier will be unconditionally stable, when the stability factor (K) and delta factor (Δ) following necessary and sufficient conditions are met:

$$K = \frac{1 - |S_{11}|^2 - |S_{22}|^2 + |\Delta|^2}{2|S_{12}S_{21}|} > 1 \tag{1}$$

And

$$|\Delta| = |S_{11}S_{22} - S_{12}S_{21}| < 1 \tag{2}$$

(K > 1) and ($|\Delta| < 1$) is condition requirement for unconditional stability.

Noise optimization is the most critical step procedure in the LNA design. The best way to make the balance optimization of noise figure and gain using constant gain circles and circles of constant noise figure. 2-port transistor has a minimum value of the noise figure at the specified admittance given by the equation (3), (Abu Bakar et al., 2011) :

$$F = F_{\min} + \frac{R_N}{G_S} |Y_s - Y_{opt}|^2 \quad (3)$$

For low noise transistors, manufacturers usually provide F_{\min} , R_N and Y_{opt} by frequencies. N defined by the formula for desired noise figure, shown in equation (4):

$$N = \frac{|\Gamma_s - \Gamma_{opt}|^2}{1 - |\Gamma_s|^2} = \frac{F - F_{\min}}{4R_N / Z_0} |1 + \Gamma_{opt}|^2 \quad (4)$$

The Power gain of 2-port networks with circuit impedance or load impedance of the power amplifier are represented with scattering coefficient classified into Available Power Gain, Power Transducer Gain and Operating Power Gain (Leon et al., 2010).

Operating power gain (G_P), is the ratio between the power delivered to the load (P_L) and the power input (P_{in}) to the network. The Operating Power Gain can be specified as an equation (5), (Abu Bakar et al., 2011) :

$$G_P = \frac{P_L}{P_{in}} = \frac{|S_{21}|^2 (1 - |\Gamma_L|^2)}{(1 - |\Gamma_{in}|^2) |1 - S_{22}\Gamma_L|^2} \quad (5)$$

Available power gain (G_A) is the ratio between the power available from the network (P_{avn}) and the power available from the source (P_{avs}) as shown in equation (6), (Abu Bakar et al., 2011):

$$G_A = \frac{P_{avn}}{P_{avs}} = \frac{1 - |\Gamma_S|^2}{|1 - S_{11}\Gamma_S|^2} |S_{21}|^2 \frac{1}{|1 - S_{22}\Gamma_L|^2} \quad (6)$$

Transducer power gain (G_T) is the ratio between the power delivered to the load (P_L) and the power available from the source (P_{in}) as shown in equation (7), (Abu Bakar et al., 2011) :

$$G_T = \frac{P_L}{P_{in}} = \frac{|S_{21}|^2 (1 - |\Gamma_S|^2)(1 - |\Gamma_L|^2)}{|(1 - S_{11}\Gamma_S)(1 - S_{22}\Gamma_L) - (S_{12}S_{21}\Gamma_S\Gamma_L)|^2} \quad (7)$$

3. DESIGN OF LNA CASCADED WITH DOUBLE STAGES CASCODED LNA

Fig. 4 shows the complete schematic single LNA cascaded with double stage cascoded LNA using inductive feedback. The selection of the transistor is important in the design of LNA. The design of the single LNA with double stages cascoded LNA is based on the specification in Table 1. For reasonable gain and low noise figure at the required frequency requirement, the transistor used for the design of LNA is PHEMT Transistor FHX76LP. The transistor parameter at frequency 5.8 GHz are $S_{11}=0.712\angle -86.54$, $S_{12}=0.065\angle 33.88$, $S_{21}=8.994\angle 178.66$ and $S_{22}=0.237\angle -10.46$, where the parameters were obtained at $V_{DD} = 2V$ and $I_{DS} = 10mA$ of bias set at PHEMT.

From the S-parameters, determining the overall performance of LNA can be determined by calculating the transducer gain (GT), noise figure (NF) and the input and output standing wave ratios, $VSWR_{IN}$ and $VSWR_{OUT}$. The optimum Γ_{opt} and Γ_L were obtained as $\Gamma_{opt} = 21 + j48.02$ and $\Gamma_L = 79.90 - j7.299$ for cascoded LNA. While, $\Gamma_{opt} = 18.41 + j50.12$ and $\Gamma_L = 79.913 - j7.304$ for a single LNA.

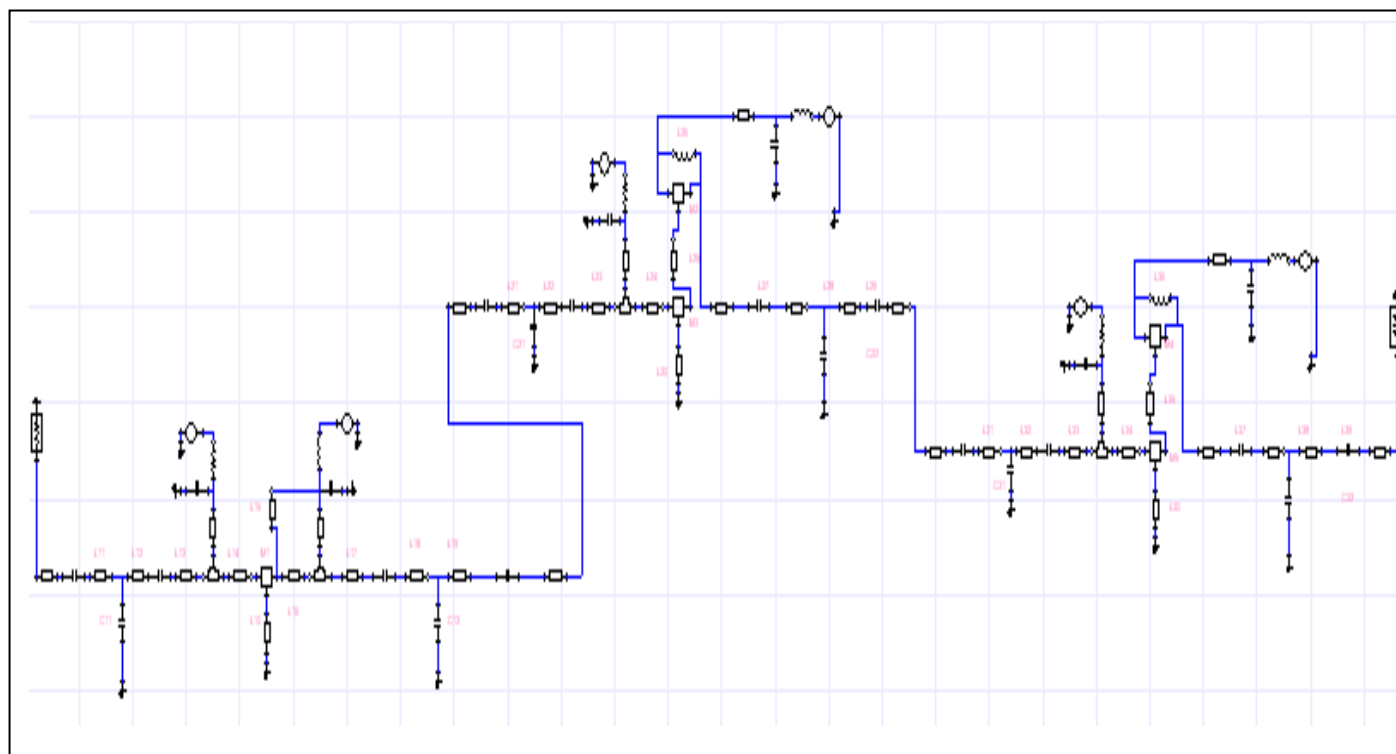

Fig 4. The complete schematic LNA cascaded with double stage cascaded LNA using inductive feedback

In this configuration, it combines LNA at the first stage, then use cascaded LNA with inductive feedback at the drain on the second and third stage. The proposed LNA design is based on a source degenerated topology (L_{10}), inductive shunt peaking at the drain (L_{15}) and T-matching network at the input and output impedance (input impedance matching at L_{11} , L_{12} , C_{11} , and output impedance matching at L_{18} , L_{19} , C_{12}). While the double stages cascaded LNA topology using latest techniques consisting of inductive feedback (L_{26} and L_{36}) are at drain M_2 and M_4 , inductive generation source (L_{20} and L_{30}) connected to the source of the M_3 and M_5 . In Addition, there L_{25} and L_{35} inductive RF choke were placed between the source drain on the M_2 and M_3 , and the source drain on the M_4 and M_5 respectively. This topology also used the T-matching network at the input and output impedance (input impedance matching component at L_{21} , L_{22} , L_{31} , L_{32} , C_{21} and C_{31} and output impedance matching component at L_{28} , L_{29} , L_{38} , L_{39} , C_{22} and C_{32}). By using Ansoft Designer SV, Smith Chart matching technique, the components for the amplifier are shown in Table 2.

Table 2. LNA Amplifier parameters

1 st Stage LNA	Components											
	L_{10} (nH)	L_{11} (nH)	L_{12} (nH)	L_{13} (nH)	L_{14} (nH)	L_{15} (nH)	L_{16} (nH)	L_{17} (nH)	L_{18} (nH)	L_{19} (nH)	C_{11} (pF)	C_{12} (pF)
Value	0.078	1.346	1.371	0.449	0.439	1.271	0.445	1.366	1.195	1.368	0.264	0.010
2 nd Stage Cascoded LNA	L_{20} (nH)	L_{21} (nH)	L_{22} (nH)	L_{23} (nH)	L_{24} (nH)	L_{25} (nH)	L_{26} (nH)	L_{27} (nH)	L_{28} (nH)	L_{29} (nH)	C_{21} (pF)	C_{22} (pF)
Value	0.064	1.346	1.016	0.698	0.367	1.159	9.000	1.367	0.658	1.369	0.100	0.600
3 rd Cascoded LNA	L_{30} (nH)	L_{31} (nH)	L_{32} (nH)	L_{33} (nH)	L_{34} (nH)	L_{35} (nH)	L_{36} (nH)	L_{37} (nH)	L_{38} (nH)	L_{39} (nH)	C_{31} (pF)	C_{32} (pF)
Value	0.084	1.318	1.278	0.658	0.283	1.139	9.560	1.368	0.658	0.228	0.500	0.750

4. RESULTS

The proposed LNA with a 3-dB bandwidth of 1.72 GHz, minimum NF of 0.64 dB, and a gain of 68.94 dB over the band is achieved. The measured return loss S_{12} is -88.39 dB while the output reflection loss S_{22} is -17.37 dB, and input reflection S_{11} is -15.77 dB. The stability factor obtained after matching load is 4.54 at 5.8 GHz frequency. The value of stability obtained is greater than 1, and the LNA amplifiers are currently in a state of unconditionally stable. Thus, these values achieved the design specification as stated in Table 2.

The output S-parameter for LNA cascaded with double stages cascaded LNA in Fig 10 (a). While noise figure and stability are shown in Fig 10 (b) and 10 (c) respectively. Table 6 shows the comparison of recently reported LNA.

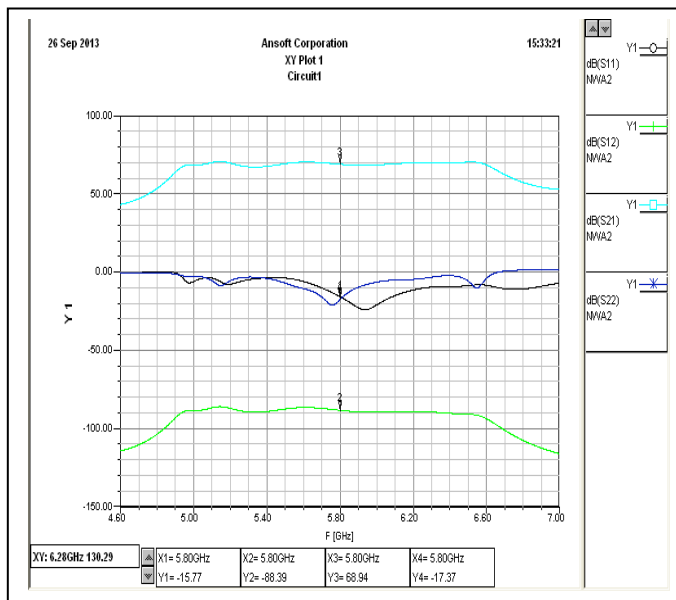

Fig 10 (a). S-parameter for LNA Cascaded with Double Stages Cascaded LNA

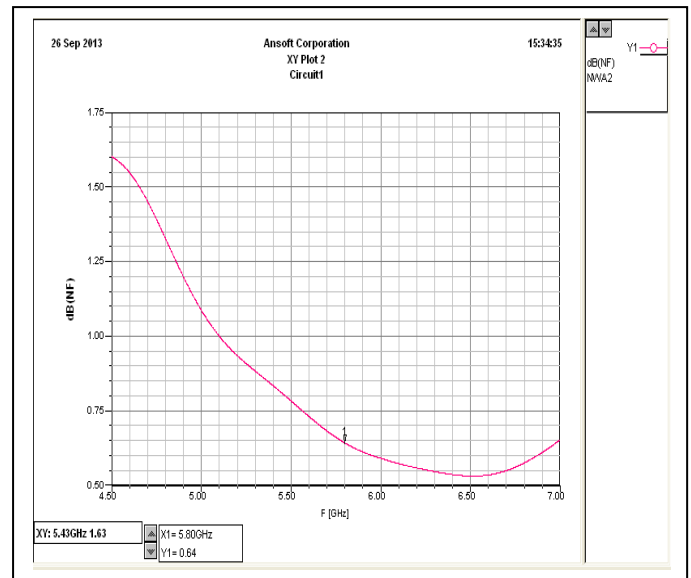

Fig 10 (b). Noise Figure for LNA Cascaded with Double Stages Cascaded LNA

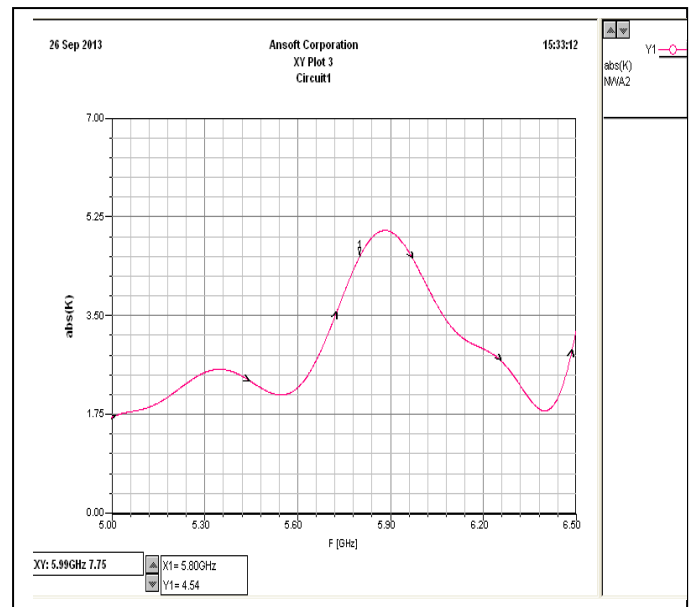

Fig 10 (c). Stability for LNA Cascaded with Double Stages Cascaded LNA

Table 4. Comparison of recently LNAs

S- parameter	This work	(Sobhy et al., 2011)	(Karpagam and Sampath, 2013)
Topology	Single LNA Cascaded with Double Stages Cascoded LNA	CGLNA with multiple feedback	Differential LNA
Input Reflection S_{11} dB	-15.77	<-10	-15.075
Output Reflection S_{22} dB	-17.37	<-10	-
Forward transfer S_{21} dB	68.94	23	25.07
Return Loss S_{12} dB	-88.39	-	-
NF dB	0.64	2	1.07
BW GHz	1.72	1.70	-
Stability (K)	4.54	>1	1.12

5. CONCLUSIONS

New topology using inductive drain feedback has been successfully developed and implemented in SuperHEMT technology. Obtained from the proposed topology allows the designer to control LNA variables performance such as noise figure, bandwidth, Gain and stability in the LNA circuit. Recorded result for amplifier obtained the noise figure (NF) of 0.64 dB and the gain (S_{21}) of 68.93 dB. While the stability (K) to 4.54 and 3-dB bandwidth is 1.72 GHz. LNA performance can be further enhanced by strengthening input and output impedance matching of the output reflection loss (S_{22}), input reflection loss (S_{11}) and return loss (S_{12}) of the respective value are -17.37 dB, -15.77 dB and -88.39 dB. In conclusion, use of this new topology has improved performance of the LNA amplifiers in RF receiver mainly on noise figure, gain, bandwidth and stability.

6. ACKNOWLEDGMENT

The work described in this paper was fully supported by Centre For Research And Innovation Management (CRIM), Universiti Teknikal Malaysia Melaka (UTeM), Melaka, Malaysia, under research grant PJP/2013/FKEKK(11C)/S01182.

REFERENCES

- [1] S. Lowe, 2007. "LTE vs WiMAX" in Hot Topics Forum: LTE vs WiMAX And Next Generation Internet, Institution of Engineering and Technology, 2007, pp. 1 –38.
- [2] A. R. Othman, A. B. Ibrahim, M. N. Husain, A. H. Hamidon, and Jsam Hamidon, 2012. Low Noise Figure of Cascaded LNA at 5.8 GHz Using T- Matching Network for WiMAX Applications. International Journal of Innovation, Management and Technology, Vol. 3, No. 6.
- [3] Abdulrahman Yarali., 2008. WiMAX: The Innovative Broadband Wireless Access Technology", Journal Of Communications, Vol. 3, No. 2
- [4] Othman A. R, Hamidon A. H, Abdul Wasli. C, Mustaffa M. F, Ting J. T. H, Ibrahim A.B, 2010. *Low Noise, High Gain RF Front End Receiver at 5.8GHz for WiMAX Application.* Journal of Telecommunication and Computer Engineering.
- [5] Somesh Kumar, Ravi Kumar., 2012. A 1.8V and 2GHz Inductively degenerated CMOS Low Noise Amplifier", International Journal of Electronics Communication and Computer Technology , Vol.2, Issue 4.
- [6] M.Pozar, David., 2001. Microwave and RF Wireless System. Third Avenue,N.Y.John Wiley & Sons.
- [7] Abu Bakar Ibrahim, Abdul Rani Othman, Mohd Nor Husain, and Mohammad Syahrir Johal, 2011. Low Noise, High Gain LNA at 5.8GHz with Cascade and Cascaded Techniques Using T-Matching Network for Wireless Applications. International Journal of Information and Electronics Engineering, Vol. 1, No. 2.,
- [8] Leon, Michael Angelo G. Lorenzo and Maria Theresa G.De., 2010. Comparison of LNA Topology for Wimax Application in a Standard 90-nm CMOS Process. 12th International Conference on Computer Modelling and Simulation. pp-642-647.
- [9] Sobhy, E.A.; Helmy, A.A.; Hoyos, Sebastian; Entesari, K.; Sanchez-Sinencio, E., 2011. A 2.8-mW Sub-2-dB Noise-Figure Inductorless Wideband CMOS LNA Employing Multiple Feedback," Microwave Theory and Techniques, IEEE Transactions on , vol.59, no.12, pp.3154,3161.
- [10] S.Karpagam, P.Sampath., 2013. A 1.8GHz Differential Low Noise Amplifier for Wireless Receivers. International Journal of Engineering Trends and Technology, Vol. 4, Issue 4.