

Determination of Pipe Deformity Using An Ultrasonic System

Sallehuddin Ibrahim, Nor Syahiran Zahidin and Mohd Amri Md Yunus
Department of Control and Mechatronics Engineering
Universiti Teknologi Malaysia
Johor, Malaysia
salleh@fke.utm.my

Abstract— Pipe deformation is of major concern as it can be an indication of pipe leakage. This paper presents an investigation using an ultrasonic system to measure the deformity on a pipe. The ultrasonic sensors are connected to aluminum probe cones which can collimate the ultrasonic signal towards the pipe surface. A deformation on the pipe will be represented by a specific voltage signal at the receiver circuit. Different weights were placed at the end of the pipe in order to make the pipe bend and thus causing deformation. Experimental result shows that the system can determine the modulus of elasticity which is identical to the predicted value. The modulus of elasticity represents the amount of deformation experienced by the pipe.

Keywords—*deformation; pipe; ultrasound*

I. INTRODUCTION

The requirement to transport fluids from the area of production to the point of end use has led to an increase in the number of pipe lines being built. Many of these pipes transport dangerous products containing toxic, sometimes near areas having high population density or via locations which are highly sensitive to environment. As there is need to protect these pipes, it is vital to have a reliable detection system installed on the pipes to detect any leaks [1].

There are several techniques to measure deformation on a pipe. Usually it is carried out by placing an electrical-resistance strain gauge on the wall surface. When a pipe is deformed, a strain will be produced and this can be detected as a change in electrical resistance which forms a strain gage[2]. Nonetheless there is a limitation in the use of strain gage. A strain gage is effective for point measurement only [3]. Not only that it can only be used only once after it exceeds its elasticity limit and after that it cannot be used anymore. As such a transducer has to be found as an alternative and one of them is ultrasonic sensor [4].

This paper expounds an investigation on the capability of an ultrasonic-based measurement system to determine the deformity of a pipe when subjected to pressure. The plate specimen to make the strain deformation is implemented at the bending pipe. In this investigation the pipe selected is of a circular shape. When the pipe is bent, strain will appear. As

the bending of the pipe is increased, more strain will be produced and analysis of the deformation can be made using several laws such as the Hooke's Law.

Ultrasonic is widely used as it provides accurate and reliable result and reliable [5]. Another advantage of using ultrasound for non-destructive testing is that the cost is much cheaper than other methods and it is simpler to operate. Distance can be measured by ultrasound [6]. As ultrasound is capable of evaluating the surface quality in terms of the internal flaw, it is also capable of measuring surface deformity caused by strain.

The benefit of using ultrasonic wave led to extensive research being carried out to utilize ultrasound in various systems as well as enhancing contemporary performance and explore new applications. Ultrasound has always been used to determine metal plate quality, scan the fetus image in the womb, and as a motion sensor in the industrial automation. There are various investigations to enhance the performance of ultrasonic devices in measuring various parameters related to the fluid flow [7] in pipe and deformation of solid medium [8]. Ultrasound is also applied in the biological field such as to determine the mechanical properties of cells using Scanning Acoustic Microscopy [9]. Even in the agricultural sector, the ultrasonic system is used by Mirzach and Flitsanov to predict shelf life and maturity of food quality for avocado [10]. It is obvious that ultrasound can be used in various applications. Ultrasonic in non-destructive testing (NDT) is popular in detecting the flaws or deformation in a plate as part of quality inspection. The plate may be a tank, pipe or others which are similar. Ultrasound can also be utilized as a motion sensor [11], where if the ultrasonic propagation is interrupted, then the system will detect the change.

II. STRAIN ON PIPE

Subjecting an object to force will result in deformation. Not only that, the shape and size of the body will also change [6]. The impact deformation on the object might be extremely small and difficult to observe or it can be very large such that the shape as well as the size of the object will change. Temperature can also cause deformation where it can cause

the object to enlarge when heat is increased or otherwise cause the body to contract when heat is reduced. The detection of deformity on a pipe surface involved a narrow range. Deformation through bending is valid only for beam and pipe is one of them. Bending deformation occurs when a long solid body is subjected to force perpendicular to their longitudinal axis. The force consists of support, slender, load and others. When the load applied on the beam, the beam at the support tries to stay fix in position while the force deflect the position of the extrude beam. In the beam deformation, there will be great shear stress to the body.

According to Hooke's law stress is proportional to strain within the elasticity limit. The law can be expressed as

$$\sigma = \epsilon E \tag{1}$$

where σ is stress, ϵ represents the strain and E is the modulus of elasticity or also known as Young's modulus.

Strain are of two types namely normal strain and shear strain. Normal strain either involved the elongation or contraction in length of a line segment per unit of length. Shear strain caused the angle to change between two line segments which were initially perpendicular to each other [6]. The characteristics of strain is different for each material. If pressure is applied, non-metals such as rubber will deform more compared to metals. The factors that influence the strain formation are pressure and modulus of elasticity. When the material has a large value of modulus of elasticity, it is more difficult to deform and it needs a higher amount of force. Similar to pressure, when pressure acting on the material increased, the body will deform to a certain value as long as it does not reach the yield limit of the material. Otherwise, it will exceed the yield point and will disobey Hooke's Law.

The schematic diagram for the experiment to observe the pipe deformation is shown in Fig. 1a. One end of the pipe is clamped to a table as shown in the left-hand side of Fig. 1a whereas the load is placed at the other end of the pipe. The load is increased gradually to observe the impact of deformation. As the load increased, the pipe will bend as shown in Fig. 1b. The upper part of the pipe will bend more compared to the lower part of the pipe. In other words, the upper part experienced tension whereas the lower part is subjected to compression. The strain caused by this phenomenon can be measured by the ultrasonic system.

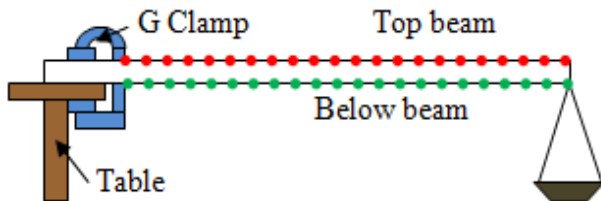

Fig. 1a. Experimental setup when there is no load

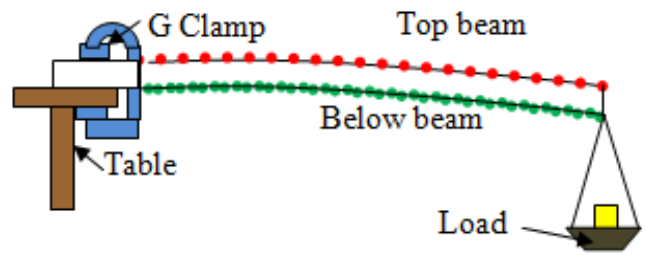

Fig. 1b. The pipe experienced deformation when a weight is placed

The pipe can be considered as a beam where the beam cross-section has a neutral line axis in the center of the beam which separates the tensile and compression region. The pipe assumed to be homogenous and the shape is symmetrical with the neutral axis across the center of origin. The further the distance from the neutral axis the greater pressure will occur and the value of strain also will be greater.

III. ULTRASONIC SYSTEM

Before you begin to format your paper, first write and save the content as a separate text file. Keep your text and graphic files separate until after the text has been formatted and styled. Do not use hard tabs, and limit use of hard returns to only one return at the end of a paragraph. Do not add any kind of pagination anywhere in the paper. Do not number text heads- the template will do that for you.

The position of the ultrasonic sensors are shown in Fig. 2. The point of detection is located 1 meter from the point where the load is placed. The distance from the point of support to the loading point is 1.1 meter. The actual experimental setup is shown in Fig. 3.

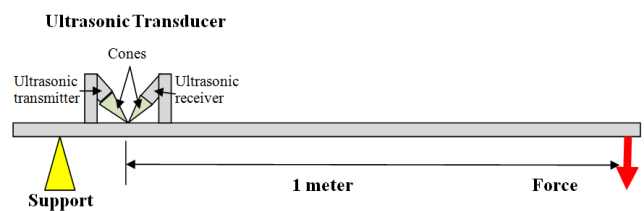

Fig. 2. A schematic diagram of the experimental setup

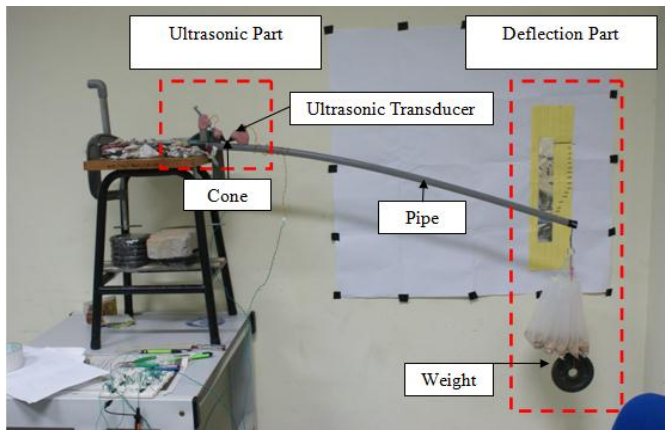

Fig. 3. Experimental arrangement

The value of strain can be calculated as follows,

$$\varepsilon = -\frac{My}{IE} \quad (2)$$

$$M = PL \quad (3)$$

where,

P = Force

L = Length, in this experiment L = 1 meter

$$\varepsilon = -\frac{PLy}{IE} \quad (4)$$

$$\varepsilon = -\frac{P(1)(10.5 \times 10^{-3})}{(5.447 \times 10^{-9})(2.9 \text{ Gpa})}$$

$$= -6.647 \times 10^{-4}$$

From equation (4), the coefficient of the equation is determined and the graph plotted should be in linear form.

The pipe cross section dimension is shown in Fig. 4. From the dimension, the moment of inertia, I, can be determined based on equation (5).

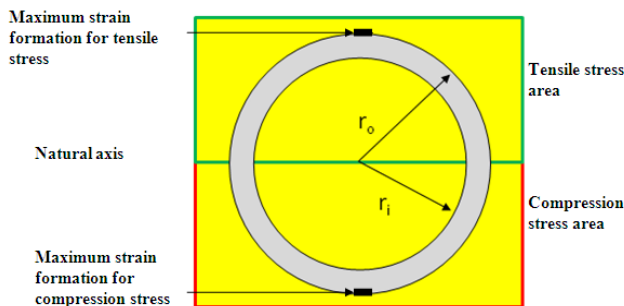

Fig. 4. Pipe dimensions

$$I = \frac{1}{4} \pi (r_o^4 - r_i^4) \quad (5)$$

$$= \frac{1}{4} \pi (0.0105^4 - 0.0085^4)$$

$$= 5.447 \times 10^{-9} \text{ m}^4$$

IV. RESULTS AND ANALYSIS

The result of the experiments are shown in Fig. 5 which shows a graph of voltage against strain for compression. Fig. 6 shows the graph of voltage against strain for tensile strain. The regression coefficient obtained from Fig. 5 is 0.97 and Fig. 6 is 0.99 which means that the graphs are linear fit. The graphs clearly show that there is a difference in the voltage values between compression and tensile strain. There is a decrease in voltage when there is an increase in strain. When the bent on the pipe is increased, the strain also increased. Further bending resulted in the distance between the ultrasonic sensor and the pipe to increase. As such this cause the distance of travel for the ultrasonic signal to increase causing the intensity of the ultrasonic signal arriving at the ultrasonic receiver to become weaker.

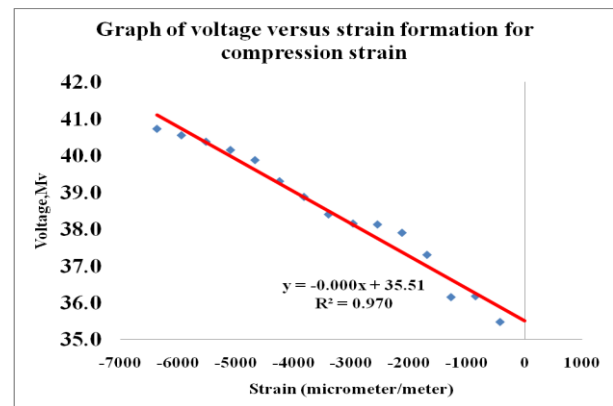

Fig. 5. Graph of voltage versus strain for compression

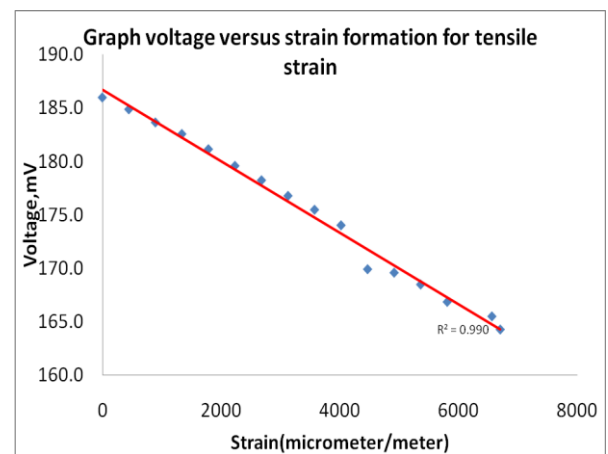

Fig. 6. Graph of voltage versus strain for tensile strain

Fig. 7 shows the graph of deflection versus $PL^3/3I$. P represents force in Newton, L is the length of the pipe in meter and I is the moment of inertia of the pipe with a unit of m^4 . From this graph the modulus of elasticity can determine for the PVC material which is material used to construct the pipe. The deflection measurement is simultaneously recorded during the experiment which recorded the voltage values. When the modulus of elasticity is obtained, it is vital to compare the value from the experiment and the standard reference value to ensure that the result is valid.

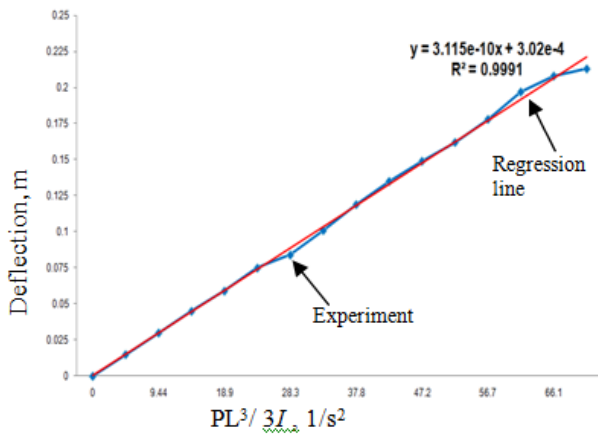

Fig. 7. The graph of deflection versus $PL^3/3I$

The graph in Fig. 7 is almost linear which shows that the deflection is proportional to $PL^3/3I$. The regression coefficient is 0.9991 which shows that the graph is linear fit. From the slope of the graph, the modulus of elasticity can be determined. From this experiment, the modulus of elasticity is found to be 3.17GPa whereas from the reference standard ASTM D638, the modulus of elasticity is 2.90GPa for PVC. Hence, the error is 9.3%. This results shows shows the ability of the system to measure the deformation occurring in the pipe.

V. CONCLUSION

A simple, low cost ultrasonic measurement system has been developed to determine the surface deformity of a pipe. The system is able to give an indication of the deformity on the pipe. Further experiments should involve varying the distance of the ultrasonic sensors from the pipe and observing

the effects on the signal received by the ultrasonic system. The reproducibility also has to be improved since the voltage corresponding to a strain of $1 \mu m/m$ is not uniform for each experiment. With this system, industries can make use of it to detect the positions where deformation or leakage occurs which enable them to make the necessary steps to prevent if from further leakages.

ACKNOWLEDGMENT

The authors would like to thank Universiti Teknologi Malaysia and the Ministry of Higher Education for their assistance in providing the fund and the facilities in conducting this research under the research grant 05H67.

REFERENCES

- [1] T. Chis, "Pipeline leak detection techniques," *Anale Seria Informatica*, vol. 5, pp. 25-34, 2007.
- [2] J. Szilard, *Ultrasonic Testing : Non Conventional*, John Wiley & Sons, 1982.
- [3] S. Shakerin, and D.D. Jensen, "Enhancement of mechanics education by means of photoelasticity and finite element method," *International Journal of Mechanical Engineering Education*, vol. 29, pp. 307-320, 2000.
- [4] J.E. Field, S.M. Walley, W.G. Proud, H.T. Goldrein, C.R. Siviour C.R, "Review of Experimental Techniques for high rate deformation and shock studies," *International Journal of Impact Engineering*, vol. 30, pp. 725-775, 2004.
- [5] J.P. Holman, *Experimental Method for Engineers*, McGraw-Hill, 2001.
- [6] R.C. Hibbeler, *Mechanic of Materials*, Prentice Hall, 2005.
- [7] R.D. Wang, Q. Liu, C.T. Du, L. Yao, "A Signal Preprocessing Algorithm Applied for Ultrasonic FlowMeter," *TELKOMNIKA Indonesian Journal of Electrical Engineering*, vol. 11, pp. 5293-5298, 2013.
- [8] Y. Wang Y, "Ultrasonic Flaw Signal Classification using Wavelet Transform and Support Vector Machine," *TELKOMNIKA Indonesian Journal of Electrical Engineering*, vol. 11, pp. 7539-7547, 2013.
- [9] T. Kundu, *Ultrasonic Nondestructive Evaluation: Engineering and Biological Material Characterization*, CRC Press, 2004.
- [10] A. Mizrach, and U. Flitsano, "Ultrasonic device for avocado shelf life predicting and maturity detection. Proceedings of the World Avocado Congress III, pp. 300-306, 1995.
- [11] J. Park J, Y. Je, H. Le, and W. Moon. "Design of an ultrasonic sensor for measuring distance and detecting obstacles," *Ultrasonic*, vol. 50, pp. 340-346, 2010.