

Design of Single Switch Resonant Converter with Parallel Load Resonant for Colour Removal in Palm Oil Mill Effluent

Mochammad. Facta; Karnoto

Electrical Engineering Department, Universitas Diponegoro,
Semarang – Indonesia
facta@elektro.undip.ac.id

Zainal Salam; Zolkafle Buntat

Universiti Teknologi Malaysia,
Skudai Johor – Malaysia

Abstract— Indonesia has palm oil harvesting as the most important agriculture crop. Unfortunately, this agricultural activity delivers a large amount of by product, known as palm oil mills effluent (POME). The treatment using membrane bioreactor has successfully removed the heavy organic component of POME but it left water in colour. This paper proposed the use of a single switch resonant converter with parallel load resonant with dielectric barrier discharge ozonizer to remove colour of treated POME. The ozonizer chamber was made from a planar metal dielectric barrier discharge construction. A single switch resonant converter as power supply to the chamber was designed and it is based on resonance principle. This circuit converted a direct current low voltage input into high frequency and sinusoidal voltage output. The high voltage created micro electrical discharges inside chamber to generate ozone from oxygen molecules. At atmospheric pressure and ambient temperature, the ozonizer deliver up to 2300 ppm ozone gas. The ozone gas was injected into the treated POME for several duration of time. The results of experiment showed that the treated POME water has successfully changed in colour from 100 mg/l Pt.Co into 20 mg/l Pt.Co or lower. As the time of treatment is increased then the colour abatement was below 15 mL/l Pt.Co.

Keywords— Color removal, silent discharge; resonant converter, ozonizer; POME.

I. INTRODUCTION

Palm oil is the most important agriculture crop in Indonesia, covering about more than three million hectares of the cultivated area. Indonesia and Malaysia remained as the world's largest producers and exporters of palm oil, because they contribute 87% of global production. Regrettably, this agricultural industry produces a great amount of by product and it is known as palm oil mills effluent (POME). The treatment conducted using membrane bioreactor has successfully removed the heavy organic component of POME but it still left water in colour as by product[1, 2]. The treated POME has brown or red dark colour because of the carotenes[3]. This carotenes, naturally, are fat-soluble and or less soluble in water. This colour is difficult to be removed by biological treatment so that it becomes an esthetical problem

in palm oil mills treatment. This coloured water later become unattractive and the major reason of complain when it is utilized. The colour removal techniques using activated carbon were reported to work, but activated carbon has very short life and must be replaced frequently. The oxidation treatment using chlorine and chloride oxide was reported adequately for colour abatement, but they have unpleasant taste and smell. Ozone gas has become a preferable choice for water and air treatment due to its less harmful effect to the environment. In this paper, ozone gas was generated by a simple ozonizer construction based on the application of electrical discharge to conduct colour removal from the result of palm oil mills effluent treatment.

Conservative ozone generation with 50 or 60 Hz high voltage power supply, the voltage injected was about 3 – 10 kVrms or 8.5 – 28 kV peak to peak [4-6]. However, in practical the injected voltage used for ozone chamber at atmospheric pressure and ambient temperature is considerable high and near to the sparking potential. The dimension of conventional power supply is in a large volume, due to the present of transformer. Regard to safety, high voltage may not be suitable for household applications.

Recently, ozone generation with 50 or 60 Hz high voltage power supply, the voltage injected was about 3 – 10 kVrms or 8.5 – 28 kV peak to peak [4, 7, 8]. This results give an increase in ozone production for a given surface area, while decreasing the require peak voltage.

The the full bridge resonant converter operated at resonant frequency of 88 kHz was reported to generate ozone from from 4 – 6 kV peak to peak [9]. The converter requires four MOSFET switches and high DC input voltage (340 Volt). A single hard switching converter driving an ozone chamber filled with special discharge gas such as X_e , A_r , or N_e operated at certain pressure. The dielectric layer was constructed in borosilicate glass or quartz with a conductive thin layer on the surface. Although the voltage reduce to 1 kVrms or 2.8 kV peak to peak and the ozone yield was high, such chamber is considered complicated to construct. [7, 10]. Planar electrodes are made from metal with borosilicate glass

as dielectric. This ozone chamber need to be operated at higher voltage (more than 7 kV) and frequencies from 5 - 7 kHz. [11-13]. Further more, the application of higher voltage result in filamentary effect inside the chamber [11, 14] and as a result a cooling system is necessary required.

The use of single switch resonant converter has been recorded to produce ozone, how ever this work require ferrite transformer to step up the voltage and it give bigger size in volume [15]. A single switch resonant converter with parallel load resonant for ozonizer in this work is constructed by two parts, first is ozone chamber and the second part is power converter with a single switch where a high voltage high frequency is generated.

II. II. OZONIZER CHAMBER

In this work, the ozone chamber is constructed by aluminium mesh as electrode and metal tape with muscovite mica sheet as dielectric material are placed between the electrodes [16]. The air gap inside chamber is 1.5 mm. Maximum operating temperature is about 500°C[17, 18]. Illustration of the chamber is shown in Figure 1.

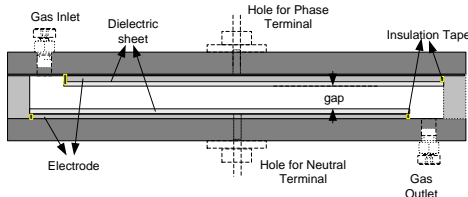

Figure 1. Ozone chamber

The dielectric layer presents between two electrodes and air gap and it gives representation of capacitance. When micro discharges occur, the current flows in through equivalent resistance. The investigation to the characteristics of the chamber as it is supplied by high voltage high frequency gives Lissajous pattern. This pattern is shown in Figure 2. Due to this electrical characteristics, the equivalence circuit of the ozone chamber is represented in parallel capacitance and reactance [19] as it is shown in Figure 3.

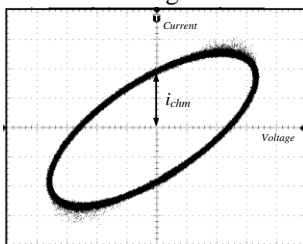

Figure 2. I-V characteristics in Lissajous Pattern

III. III. DESIGN OF SINGLE SWITCH RESONANT CONVERTER

Single switch resonant converter (SSRC) is the most interesting because it utilises only one power semiconductor switch and therefore exhibits low power losses [20]. The basic circuit of SSRC is illustrated in Figure 4. The circuit consist of a DC side which comprises of solid state MOSFET (M1), a choke inductor (Lf), and a shunt capacitor (C1). The AC side

consist of several passive component R, L, and C which represent a resonant circuit.

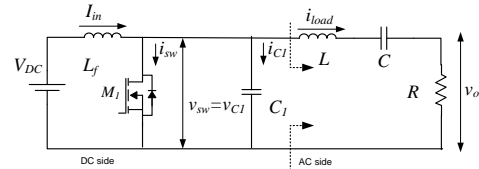

Figure 4. Fundamental Circuit of Single Switch Resonant Converter

Parallel loaded circuit shown in Figure 5, is possible to be made from inductor with ferrite core as series resonant inductor connected to ozone chamber. By considering that the equivalent circuit of ozone chamber consist of parallel capacitance and resistance and it act as parallel load, when this circuit combine with ferrite inductor, they made parallel loaded resonant circuit. This PLRC is able to deliver high voltage from lower voltage then the combination of this resonant circuit as AC part of single switch resonant converter.

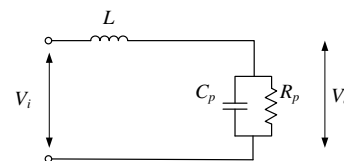

Figure 5. Equivalent Circuit of Ozone Chamber as part of Parallel Loaded Resonant Circuit

Theoretically, the parallel loaded circuit will gives voltage attenuation as Equation (1):

$$|G| = \frac{1}{\sqrt{(n^2 - 1)^2 + \left(\frac{n}{Q}\right)^2}} \tag{1}$$

where Q is quality factor, and n is the ratio between actual frequency and resonant frequency. Gain voltage as the function of frequency is illustrated in Figure 6. The maximum voltage is possible to achieve eight time of input voltage.

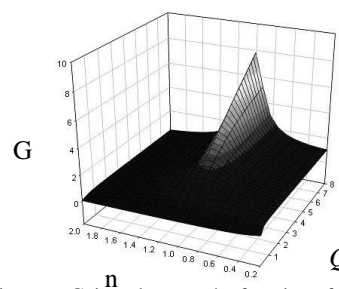

Figure 6. Gain voltage as the function of frequency

When a ferrite inductor with 9.75 mH is connected to ozone chamber with internal capacitance 0.12nF, and equivalent resistance in the range of 150 kΩ up to 220 kΩ, the resonant frequency is 147.1 kHz according to Equation (2).

$$f_o = \frac{1}{2\pi\sqrt{LC_{ch}}} \tag{2}$$

To increase the loaded quality factor (Q) and decrease the frequency, additional 2.94nF high voltage capacitor (C_a) is put in parallel to the ozone chamber as shown in Figure 7. It improves the loaded quality factor in the range of 84 to 123 and decreases the resonant frequency to 29.1 kHz.

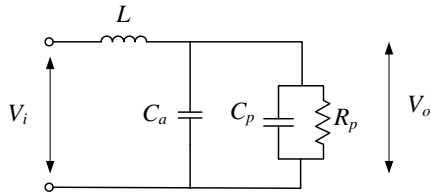

Figure 7 Modified Parallel Loaded Resonant Circuit with additional high voltage capacitor (C_a)

By using frequency sweep program in Microsim, the simulation result of parallel loaded resonant with additional capacitor (C_a) is shown in Figure 8. It shows that in interval frequency 28 – 29 kHz, the output voltage can achieve more than 2kV peak. This voltage is considered sufficient to initiate and maintain the silent discharge inside the chamber, although the internal resistance decrease when the ozone formation increase.

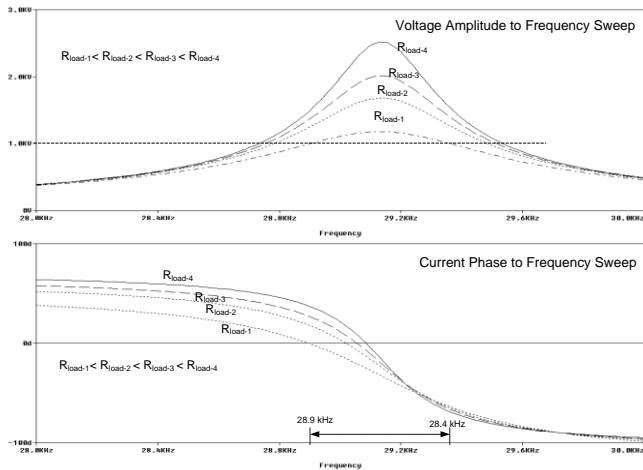

Figure 8 Simulation Result of Frequency Sweep Program

IV. EXPERIMENTAL SETUP

The experimental setup of the complete ozonizer for colour removal of palm oil effluent is shown in Fig. 9. The resonant converter consists of PWM IC to tune converter near resonance and to get high voltage output, MOSFET, variable DC source (30 – 60 Volt), ozone chamber, oxygen supply, oscilloscope TDS3034B, high voltage probe, current probe, reaction tank with the effluent, ozone monitor, and ozone destructor. The samples of treated POME was put into the sealed tank. A diffuser was connected to the output of ozone chamber through polytherane pipe and sunk inside reaction tank. This diffuser created bubbles when ozone was injected. Oxygen as an input gas was injected at 1 liter per minute, then the high frequency power supply was switched on. The desired ozone dosage was set by the amplitude of sinusoidal voltage through the variable DC source. Every sample of treated POME which was injected by ozone in the certain contact time was measured. The water colour of treated

POME was measured with a spectrophotometer using ADMI method (HACH/DR5000)

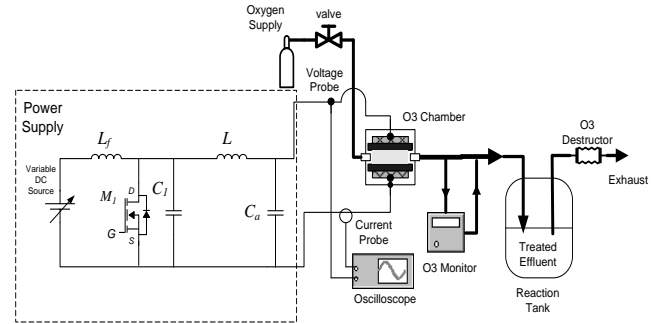

Figure 9. Experimental Set Up of ozonizer for Colour Removal

V. RESULT AND DISCUSSION

At resonant frequency 29.3 kHz, the sinusoidal output voltage was obtained up to 3 kV_{p-p} as shown in Figure 10 (a), meanwhile the voltage at low voltage side is shown in Figure 10 (b).

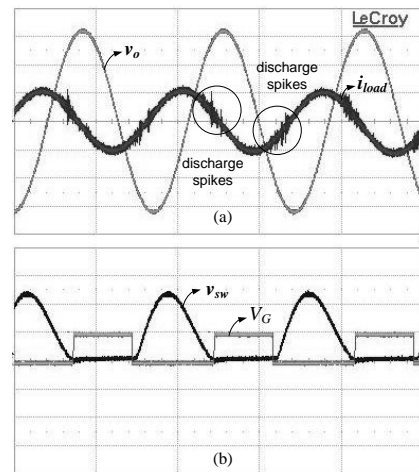

Figure 10.a Output voltage at terminal chamber Voltage (500V/div) and Current (50mA/div) at chamber side; 10.b. control signal, v_{sw} (20 Volt/div) and voltage at low voltage side, V_G (50V/div)

The circuit gives maximum ozone concentration 2300 ppm or 4.90 g/m³ at 3.2 kV_{p-p}. as it is shown in Figure 11.

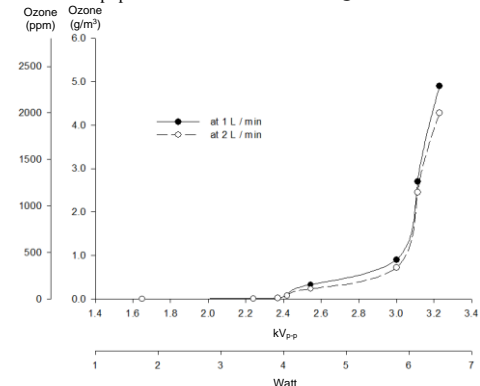

Figure 11. Ozone Concentration in ppm as a function of applied voltage in Volt

Figure 12 shows that by increasing the ozone concentration for constant contact time, there is a trend to achieve lower

water colour in PtCo. The colour removal process reaches 15mg/L PtCo or lower as it is recommended by World Health Organization (WHO) for drinking water.

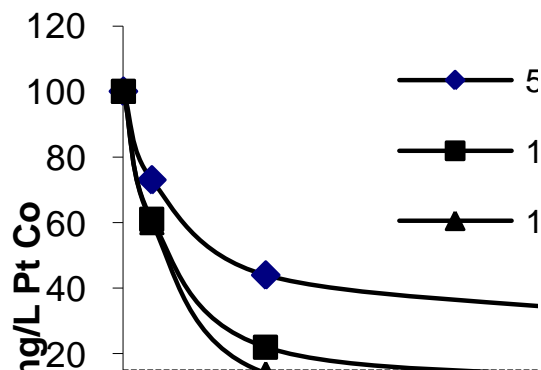

Figure 12. Colour removal as the function of dosage of ozone injection at different contact time

CONCLUSION

1. An ozonizer constructed with single switch resonant converter with parallel load has produces ozone gas up to 2300 ppm or 4.90 g/m³ at 3.2 kV_{p-p}.
2. The use of modified Parallel Loaded Resonant Circuit has been effectively magnify the dc input voltage 26 Volt to maximum voltage 3.2 kV_{p-p}.
3. The ozone gas has been effectively injected into the reaction tank to remove colour of liquid result from treatment POME.. The water colour removal process achieved below 20 mg/l PtCo in 5 minute. As the contact time is extended up to 15 minute, then 15 mg/L Pt.Co was achieved.

References

[1] Ahmad. A.L., *et al.*, "Membrane treatment for palm oil mill effluent: effect of transmembrane pressure and crossflow velocity," *Desalination*, vol. 179, pp. 245-255, 2005.

[2] Yuniarto. A, *et al.*, "Bio Fouling reducer in submerged membrane bioreactor for palm oil mill effluent treatment," presented at the International Conference and Expo on Environmental Management and Technology (ICEEMAT'08), Malaysia, 2008.

[3] Ahmad. A.L. , *et al.*, "Recovery of oil and carotenes from palm oil mill effluent (POME)," *Chemical Engineering Journal*, vol. 141, pp. 383-386, 2008.

[4] Kogelschatz. U. and B. Eliasson, "Ozone generation and application," ed New York: Marcel Dekker, 1995, pp. 581 – 605.

[5] Alonso. J. Marcos, *et al.*, "High Frequency Testing and Modeling of Silent Discharge Ozone Generators," *Ozone: Science and Engineering*, vol. 25, p. 14, October 2003.

[6] Mohammad A.T. Alsheyab and Aurelio H. Muñoz, "Optimisation of ozone production for water and

wastewater treatment," *Desalination*, vol. 217, pp. 1-7, 2007.

[7] Alonso. J. Marcos, *et al.*, "Analysis, Design, and Experimentation of a High-Voltage Power Supply for Ozone Generation Based on Current-Fed Parallel-Resonant Push-Pull Inverter," *IEEE transactions on industry applications* vol. 41, September/October 2005.

[8] M. Facta., *et al.*, "Application of Resonant Converter in Ozone Generator Model," *Journal of Telkomnika*, vol. 6, pp. 33-38, 2008.

[9] Nisoa. M., *et al.*, "Development of High Voltage High Frequency Resonant Inverter Power Supply for Atmospheric Surface Glow Barrier Discharges," *Solid State Phenomena*, vol. 17, pp. 81-85, 2005.

[10] Alonso. J. Marcos., *et al.*, "Low-Power High-Voltage High-Frequency Power Supply for Ozone Generation," *IEEE Transaction on Industry Application*, vol. 40, March/April 2004.

[11] Koudriavtsev. Oleg., *et al.*, "A Novel Pulse-Density-Modulated High-Frequency Inverter for Silent-Discharge-Type Ozonizer," *IEEE Transaction on Industry Application*, vol. 38, March/April 2002.

[12] T. Fujishima, *et al.*, "Ozone and NO Generation Using High Frequency Dielectric Barrier Discharge," presented at the the XIVth International Symposium on High Voltage Engineering, Tsinghua University, Beijing, Cina, 2005.

[13] Jitsomboonmit, *et al.*, "Design of high voltage medium frequency power supply for plasma application," presented at the 33rd Congress On Science & Technology of Thailand, 2006.

[14] Buntat. Zolkafle., *et al.*, "Ozone generation using atmospheric pressure glow discharge in air," *J. Phys. D: Appl. Phys.*, vol. 42, p. 5, 2009.

[15] Facta. Mochammad, *et al.*, "Silent Discharge Ozonizer for Colour Removal of Treated Palm Oil Mill Effluent using A Simple High Frequency Resonant Power Converter " in *IEEE International Conference on Power and Energy (PECon)*, Selangor, Malaysia, 2010, pp. 39 - 44.

[16] M. Facta., *et al.*, "A New Type of Planar Chamber for High Frequency Ozone Generator System," *Advanced Materials Research* vol. Vol. 896 pp. 726-729, 2014.

[17] S. O. Kasap, *Principles of Electronics Material and Devices*, 3 ed.: Mc Graw Hill, 2005.

[18] N. H. Malik, *et al.*, *Electrical Insulation in Power System*. New York: Marcel Dekker, 1998.

[19] M. P. Silva, *et al.*, "Single Switch Power Supply based on the Class E Shunt Amplifier for Ozone Generator," presented at the 38th Power Electronics Specialist Conference, Florida, USA, 2007.

[20] M. K. Kazimierczuk and D. Czarkowski, *Resonant Power Converter*: John Wiley and Sons, 1995.