

Transient Stability Enhancement Using Phasor Model of Superconducting Magnetic Energy Storage

Mohamed Bey, Mohamed Moudjahed

Laboratoire de Génie Energétique et Génie Informatique,
Ibn Khaldoun University, Tiaret, 14000, Algeria
e-mail: mohamed.bey@univ-tiaret.dz

Abstract

Superconducting Magnetic Energy Storage (SMES) is one of most important device attracting researchers for enhancing the transient stability of power systems. To facilitate the use of this device in different simulations and studied, a phasor model is established and used to analyse the impact of this device using matlab/Simulink software. The phasor model has enough advantages like using the SMES without need detailed model that contains the electronic power converter and therefore minimize the simulation time. The Western Systems Council Coordinating (WSCC) 3 machine-9 bus system is taken as a power system test. Simulation results show that the phasor model of SMES unit is very effective to study their impact for enhancing the transient stability in large scale time.

Keywords: SMES, Phasor Model, Simulation Time, Transient Stability

1. Introduction

Due to the development of electric power networks, the control becomes more and more delicate in this situation a lot of researches are established to better controller as FACTS and storage energy devices [1].

Superconducting Magnetic Energy Storage (SMES) is one of solutions proposed in order to maintain the stability of electric networks because of their effectiveness designed by their very short response time [2]. The SMES is a superconducting coil can store electrical energy in a magnetic field with no active losses [3].

With the development of electronic power converter, the use of SMES and other systems of FACTS becomes more and more possible. But the problem with conventional methods of analysis systems to study the impact of these devices on electrical systems through the use of detailed model is the simulation time because of the use of nonlinear systems such as electronic power converter. Using the detailed model requires a study of the systems in short time scales and especially when the system is complicated as multimachine power system, simulation becomes more and more slower, hence the results obtained do not give a precise idea on the principals parameters of electric network as the load angle or voltage bus and their variation in time, because of this, looking for a method or equivalence to the device in order to allow us to the studies in large scales of time should be required. In this paper we established a new model of SMES which based on the method of phasor model that has been proposed by matlab in some electrical systems such as FACTS [4], [5]. This facilitates the study of SMES in large scale time and minimizes the simulation duration [6], [7]. To prove the effectiveness of this method, the proposed model was applied on a multimachine power network.

2. Modeling of SMES Unit

Figure 1 shows the configuration of the SMES unit. The unit contains Y-Y/Y- Δ connected transformer, a 12-pulse converter and a DC Superconducting inductor. The control of the firing angles α_1 and α_2 of the bridges makes the SMES have the ability to control active and the reactive power independently and rapidly within circular range containing four quadrants of the power domain [8], [9], [10].

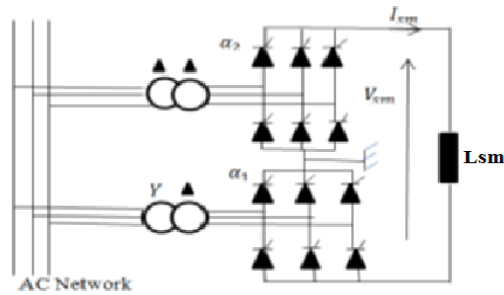

Figure 1. The configuration of SMES unit

The voltage V_{sm} of the DC side of the 12-pulse converter is expressed by

$$V_{sm} = V_{sm0}(\cos\alpha_1 + \cos\alpha_2) \quad (1)$$

V_{sm0} is the ideal no-load maximum DC voltage of the 6-pulse bridges. The current and voltage of superconducting inductor are related as

$$I_{sm} = \frac{1}{L_{sm}} \int V_{sm} dt + I_{sm0} \quad (2)$$

I_{sm0} is the initial current of the inductor.

The real and reactive power absorbed or delivered by the SMES unit are

$$P_{sm} = V_{sm0}I_{sm}(\cos\alpha_1 + \cos\alpha_2) \quad (3)$$

$$Q_{sm} = V_{sm0}I_{sm}(\sin\alpha_1 + \sin\alpha_2)$$

The energy stored in the superconducting inductor is:

$$W_{sm} = W_{sm0} + \int_{t_0}^t P_{sm} d\tau \quad (4)$$

W_{sm0} is the initial energy in the inductor. It is such as:

$$W_{sm0} = \frac{1}{2} L_{sm} I_{sm0}^2 \quad (5)$$

For ΔV_t the voltage deviation at the terminal bus of the generator because of sudden change in the system, the desired Q_{sm} -modulation of the SMES unit is:

$$Q_{sm} = \frac{K_{vs}}{1+sT_{dc}} \Delta V_t + Q_{sm0} \quad (6)$$

Q_{sm0} is the reactive power of the SMES before the fault and K_{vs} , is the amplifier gain. T_{dc} is the delay time of the converter.

For $\Delta\omega$ the speed deviation, the active power modulation of the SMES unit P_{sm} is:

$$P_{sm} = \frac{K_{ps}}{1+sT_{dc}} \Delta\omega + P_{sm0} \quad (7)$$

P_{sm0} is the active power of the SMES before the fault and K_{ps} is the gain of the amplifier. T_{dc} is the delay time of the converter.

To meet the physical aspect of SMES, use limiters voltage and current is required.

Figure 2 shows the transfer function of SMES unit for reactive and active power respectively which can obtain from the equations (2) (4-7).

By knowing P_{sm} and Q_{sm} desired, and with using equation (3), the firing angle of the converter under four quadrant operations can be calculated [8], [9] as

$$\alpha_1 = \cos^{-1}\left(\frac{P_{sm}}{P_{sm}^2 + Q_{sm}^2}\right) + \cos^{-1}\left(\frac{P_{sm}^2 + Q_{sm}^2}{2V_{sm0}I_{sm}}\right)$$

$$\alpha_2 = \cos^{-1}\left(\frac{P_{sm}}{P_{sm}^2 + Q_{sm}^2}\right) - \cos^{-1}\left(\frac{P_{sm}^2 + Q_{sm}^2}{2V_{sm0}I_{sm}}\right)$$
(8)

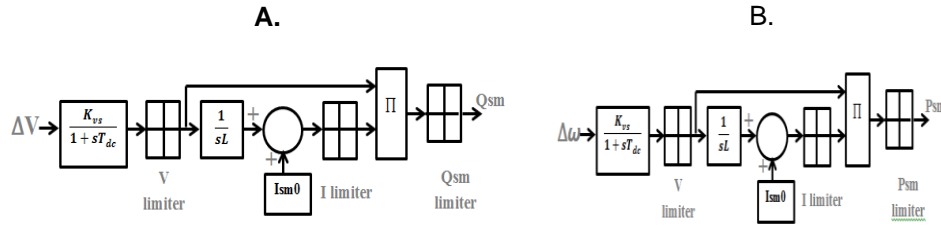

Figure 2. A) Reactive part of S-block of SMES unit B) Active part of S-block of SMES unit

3. Phasor Model of SMES

Phasor method is based on the development of Fourier series, it was proposed by matlab/Simulink to solve the problem of simulation time when the system is complicated or there are nonlinear systems in the model such as FACTS devices that are based on static converters [4].

Figure 3 shows the detailed model of phasor type of SMES, including the measurements systems and transforms, calculation of reference current, control method with a simple PI controller, the equivalent AC converter. The SMES is modelled as current source connected with power system in parallel and the active and reactive components of the current source can be controlled independently [6], [11].

Based on investigations of Performance of UPFC without DC link capacitor [12], [13], and on decoupled control method [14]. The instantaneous power is modified and obtained in terms of d-q quantities as

$$P = \frac{3}{2} V_d \cdot I_d$$
(9)

$$Q = \frac{3}{2} V_q \cdot I_q$$

From equations (9) the required current References are calculated as follows:

$$I_d^* = \frac{2 P^*}{3 V_d}$$

$$I_q^* = \frac{2 Q^*}{3 V_q}$$
(10)

Where P^* and Q^* are the reference active and reactive power which are to be exchange by the SMES unit and the transmission line.

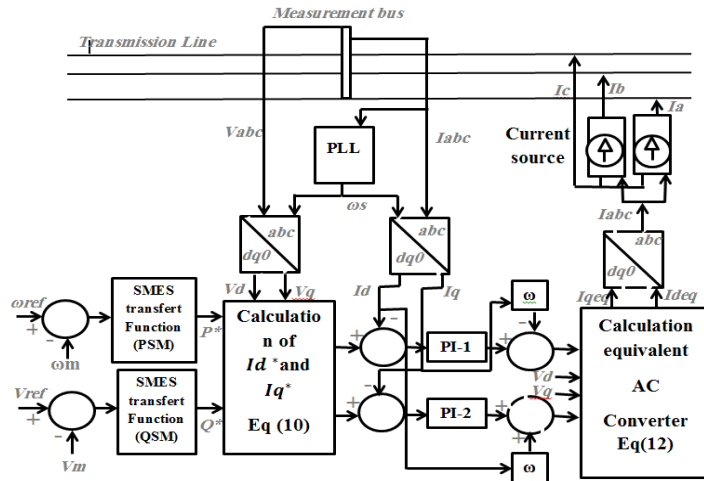

Figure 3. SMES detailed phasor type with decoupled method controller

4. Equivalent Converter System

For injecting the currents obtained after application of the control system it is first necessary to calculate the equivalent AC converter which modelled as R-L series circuit for each phase. The mathematic model of three phase series R-L circuit [6]-[15], in d q axis can be described as:

$$V_d - V_d^* = RI_d - \omega LI_q + L \frac{dI_d}{dt} \tag{11}$$

$$V_q - V_q^* = RI_q - \omega LI_d + L \frac{dI_q}{dt}$$

Using Laplace transforms and per unit (pu) quantities, Equation (9) can be arranged as

$$I_d = \frac{\omega}{sL}(V_d - V_d^* - RI_d + LI_q) \tag{12}$$

$$I_q = \frac{\omega}{sL}(V_q - V_q^* - RI_q + LI_d)$$

By using equation (10), we can calculate the equivalent d q current and inject it in the transmission line using current source element.

5. Simulation, Result and Discussion

Figure 4 shows the studied system Implement in Sim Power Systems which consists of a 3 machines and 9 buses where M1, M2 and M3 are the generators of the power system equipped with a classical regulation and the loads 1, 2 and 3 connected respectively to the bus 5, 6 and 7. The simulated fault is a three-phase short circuit to ground in line 5-7 at 25% near the bus 7 started at 0.2s with duration of 200ms. The optimal position of the SMES to improve the system stability depends on the fault's location [16], [17]. In this case, the SMES unit must be connected to the bus 2. ALL the data of the system is given in the Appendix A, B, and C.

A series of simulations has been carried out by using the model corresponding to the equivalent scheme of Figure 4. The simulation is implemented by using matlab/Sim Power Systems which the simulation time used is (7sec).

The simulation was done in three steps, the first one is to have the behaviour of the system studied without any regulation, the second one we introduce only the conventional regulation. The final step, and since the fault is close to the generator 2 or it is the most disrupt we introduce the SMES in bus 2.

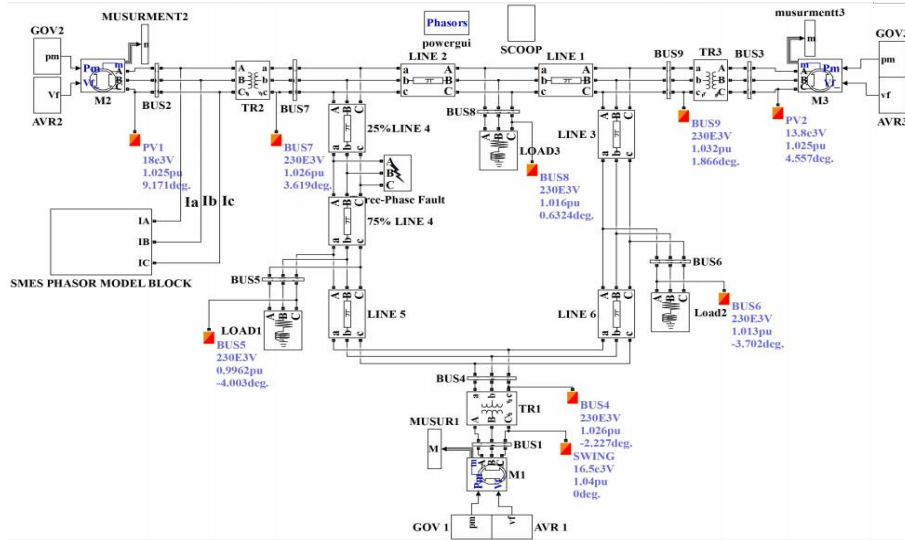

Figure 4. WSCC 3 machine-9 bus System with SMES unit in MATLAB /SimpowerSystems.

Firstly, Figure 5 shows the variation in the reactive power according to active power. It's the most important result to confirm the model as a phasor model of the SMES; it demonstrate that the operation of the model is made in four quadrants of the exchange of power between the SMES and the network which is the characteristic of SMES unit based on 12-pulse converter.

Figure 6 shows the control of firing angle α_1 and α_2 which are calculate by using equation (8), it's very clearly that the control was made on unequal alpha mode and the obtanied result can compare with [9].

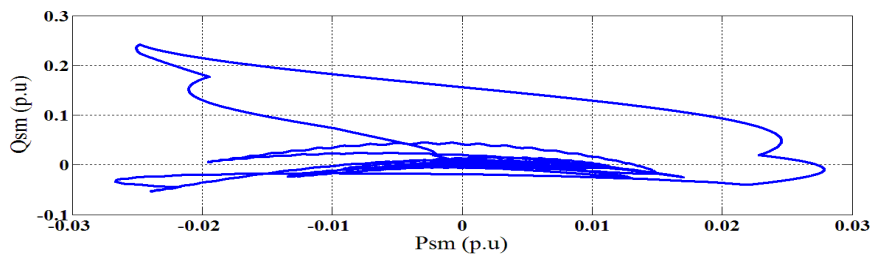

Figure 5. QSM in terms of PSM

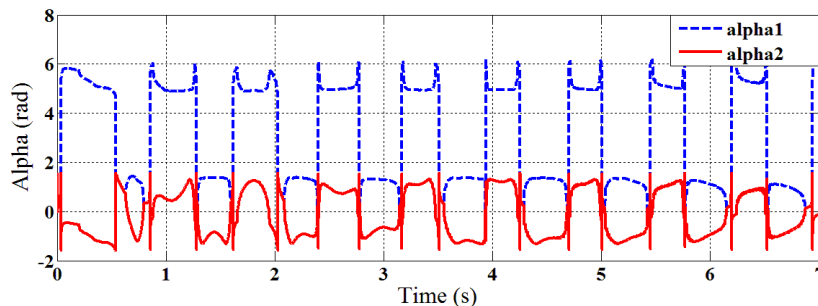

Figure 6. Firing angle α_1 and α_2

Secondly, to see the effectiveness of the phasor model of SMES in this study a comparison between results has been obtained in the different mode of simulation.

Figures 7, 8 and 9 shown the system performances without any regulation, with classical regulation and with the SMES unit applied in bus 2, the figures represented respectively load angle in degree, the rotor speed and the voltage in (p.u) on bus 2.

It is observed that the use of classical regulation and SMES unit improves the system damping; it's very clearly that the settling time of SMES is a bit worse than of only conventional regulation, the addition of the SMES unit improves the system damping and the settling time decreases substantially.

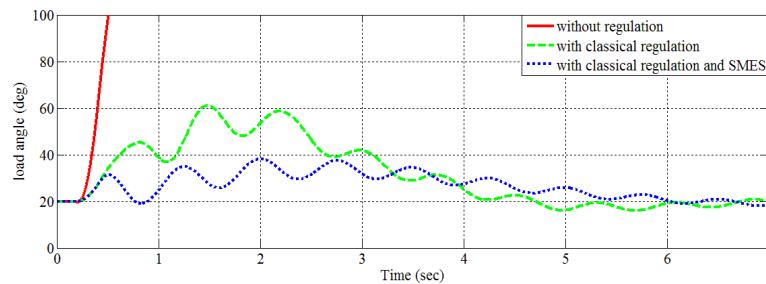

Figure 7. Load angle (deg)

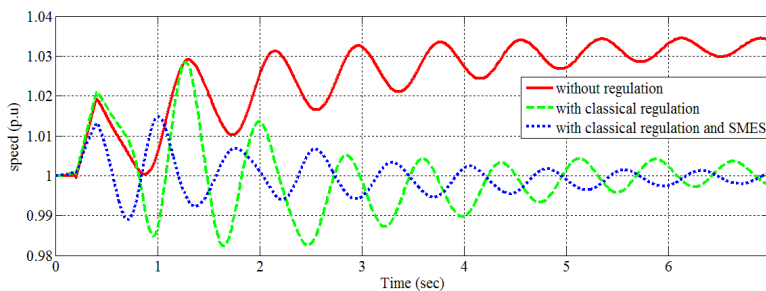

Figure 8. Rotor speed (p.u)

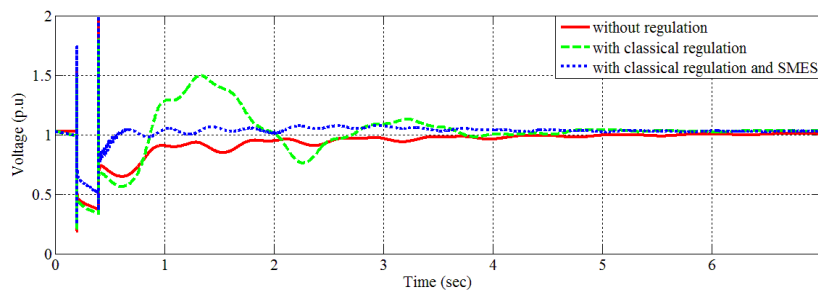

Figure 9. Voltage (p.u)

Figures 10 and 11 shown the active and reactive power exchanged with the SMES unit respectively. This corroborates the power release/absorption properties of the SMES unit. Before the dynamic period, there is no change, during the dynamic period, the SMES unit releases power to the system to contribute to its stabilization.

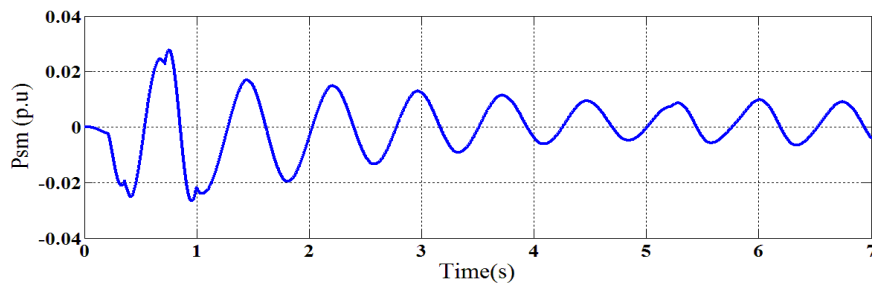

Figure 10. Active power of SMES (p.u)

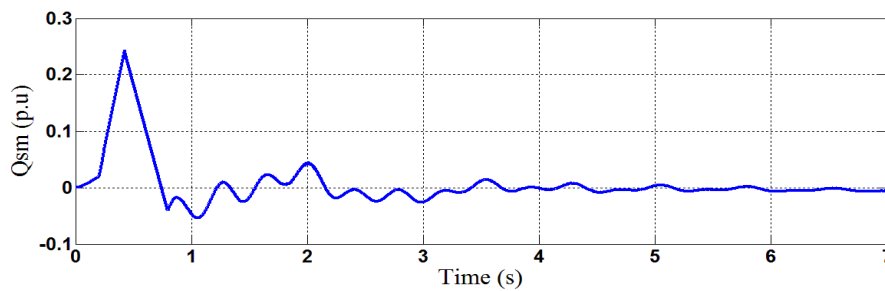

Figure 11. Reactive power of SMES (p.u)

5. Conclusion

To ease the study of the impact of SMES unit in the transient stability of electric power network in large scale of time, a phasor model of this device is proposed in this paper. The model enables a quick and efficient simulation. We demonstrate that the phasor model of the SMES has a capacity of response extraordinary. With this model the control of SMES can be easily applied. Simply the phasor model of the SMES offers the possibility to treat this device, whatever the complexity of the system, and the simulation duration. The next job is to apply another method of control, and other type of study and compare the results obtained by this model with that of the detailed model.

Appendix

A -Classical regulation

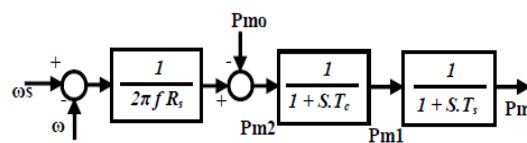

Bloc diagram for a representation of speed regulation.

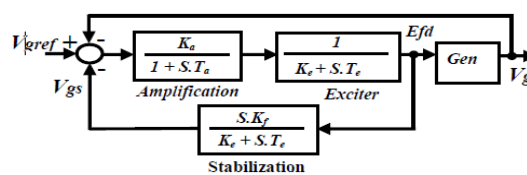

Bloc diagram for a representation of voltage regulation.

B-SMES parameters

L_{sm}=0.15pu, T_{dc}=0.02s, K_{ps}=14, K_{vs}=2.4,
P_{sm}=-3pu, P_{smax}=3pu, Q_{smin}=-3pu, Q_{smax}=3pu,
K_p =120, K_i 30.

C-Data of studied system:

f=60 Hz, Length = 100km for all line. P_n = 100MVA

Table 1. Load parameters

Load bus	5	6	8
P (MW)	125	90	100
Q (MVAR)	50	30	35

Table 2. Generator parameters

Generator	1	2	3
V _n (Vrms)	16.5 e3	18 e3	13.8 e3
X _l (p.u)	0.05	0.05	0.05
X _d (pu)	0.146	0.8958	1.3125
X _{d'} (pu)	0.0608	0.1198	0.1813
X _{d''} (pu)	0.005	0.005	0.005
X _q (p.u)	0.0969	0.8645	1.2578
X _{q'} (p.u)	0.0969	0.1969	0.25
X _{q''} (p.u)	0.005	0.005	0.005
T _{do} (s)	8.96	6.0	5.89
T _{d'o} (s)	0.01	0.01	0.01
T _{qo} (s)	0.5	0.535	0.6
T _{q'o} (s)	0.001	0.001	0.001
H (s)	23.64	6.4	3.01

Table 3. Line parameters

Line	r1r0(Ohms/km)	l1 l0 (H/km)	c1 c0 (F/km)
1	0.0629 0.1573	1.41e-3 3.53e-3	10.47e-9 06.15e-9
2	0.0449 0.1124	1.01e-3 2.02e-3	7.471e-9 04.39e-9
3	0.2063 0.5157	2.38e-3 6.09e-3	17.95e-9 10.55e-9
4	0.1692 0.4232	2.25e-3 5.64e-3	15.34e-9 09.02e-9
5	0.0529 0.1322	1.19e-3 2.38e-3	08.82e-9 05.18e-9
6	0.0899 0.2248	1.29e-3 3.22e-3	7.922e-9 04.7e-9

Table 4. Speed governor parameters

GOV	1	2	3
R _s	-0.04	0.05	0.06
T _c (s)	-0.04	0.05	0.06
T _s (s)	-0.04	0.05	0.06

References

- [1] Bindeshwar S, Verma KS, Pooja M, Rashi M, Utkarsha S, Aanchal B. Introduction to FACTS Controllers: A Technological Literature Survey. *International Journal of Automation and Power Engineering*. 2012; 1(9): 193-234.
- [2] John DR, Robert IS, Barry LM, John FH. 30-MJ Superconducting Magnetic Energy Storage System for Electric Utility Transmission Stabilization. *Proceedings of the IEEE*.1983; 71(9): 1099-1107.
- [3] Chen L, Liu Y, Arsoy AB, Ribeiro PF, Steurer M, Iravani MR. Detailed Modeling of Superconducting Magnetic Energy Storage (SMES) System. *IEEE Transactions on Power Delivery*. 2006; 21(2): 699-710.
- [4] Matlab/Simulink guide, Sim Power Systems Section, [Online]. Available: <http://www.mathworks.com/products/simpower/>.
- [5] Hannan MA, Chan KW. *Modern power systems transients studies using dynamic phasor models*. International Conference on Power System Technology. Singapore. 2004; 2: 1469–1473.

- [6] Shi J, Tang Y, Ren L, Li J, Chen S. The phasor type model of SMES. *Physica C: Superconductivity*. 2009; 469(15-20):n1785–1788.
- [7] Zhijun E, Chan KW, Fang DZ. Dynamic Phasor Modelling of TCR based FACTS Devices for High Speed Power System Fast Transients Simulation. *Asian Power Electronics Journal*. 2007; 1(1): 42-48.
- [8] Qli-Jui W, Yuanp Shung L. Application of Superconducting Magnetic Energy Storage Unit To Improve The Damping of Synchronous Generator. *IEEE Transactions on Energie- Conversion*. 1991; 6(4): 579-578.
- [9] Rabbani MG, Devotta JBX, Elangovan S. Application of Simultaneous Active and Reactive Power Modulation of SMES Unit under Unequal α -Mode for Power System Stabilization. *IEEE Transactions on Power Systems*. 1999; 14(2): 547-552.
- [10] Moudjahed M, Kauffmann JM. Simulation of Power System Stability by Using Superconducting Magnet Energy Storage. *International Journal of power and Energy System*. 1996; 16(3): 145-150.
- [11] Shirai Y, Nitta T, Akita K, Nishikaito H. *Experimental studies on diagnosis of operating conditions of power system by use of SMES in Power System Simulator*. 4th International Conference on Advances in Power System Control, Operation and Management. APSCOM. 1997; 2: 585-590.
- [12] Padma S, Lakshmipathi R, Kumar KR, Nandagopa P. A PI Controller for Enhancing the Transient Stability of Multi Pulse Inverter Based Static Synchronous Series Compensator (SSSC) With Superconducting Magnetic Energy Storage (SMES). *International Scholarly and Scientific Research & Innovation*. 2010; 4(3): 629-635.
- [13] Geethalakshmi B, Dananjayan P. Investigation of performance of UPFC without DC link capacitor. *Electric Power Systems Research*. 2008; 78(4): 736–746.
- [14] Jing S, Yuejin T, Li R, Li J, Shijie Ch. Discretization-Based Decoupled State-Feedback Control for Current Source Power Conditioning System of SMES. *IEEE Transactions on Power Delivery*. 2008; 23(4): 2097-2104.
- [15] Laouarem S, Madani L, Belkhiat S. *Contrôle de la puissance active et réactive instantanée par source d'énergie type SMES*. 4th International Conference on Computer Integrated Manufacturing. 2007.
- [16] Xiaohua H, Guomin Z, Liye X. Optimal Location of SMES for Improving Power System Voltage Stability. *IEEE Transactions on Applied Superconductivity*. 2010; 20(3): 1316-1319.
- [17] Lin Z, Min Y. *Selecting the location and the capacity of SMES for on line steady state security assessment of power systems*. IEEE International Conference on Electric Utility Deregulation, Restructuring and Power Technologies. Hong Kong, China. 2004; 2: 606 – 610.